

CSIE30600/CSIEB0290  
Database Systems

**Lecture 9:  
ER/EER to Relational  
Mapping**

## Outline

- **ER-to-Relational Mapping Algorithm**
  - Step 1: Mapping of Regular Entity Types
  - Step 2: Mapping of Weak Entity Types
  - Step 3: Mapping of Binary 1:1 Relation Types
  - Step 4: Mapping of Binary 1:N Relationship Types.
  - Step 5: Mapping of Binary M:N Relationship Types.
  - Step 6: Mapping of Multivalued attributes.
  - Step 7: Mapping of N-ary Relationship Types.
- **Mapping EER Model Constructs to Relations**
  - Step 8: Options for Mapping Specialization or Generalization.
  - Step 9: Mapping of Union Types (Categories).

CSIE30600/CSIEB0290 Database Systems ER/EER to Relational Mapping 2

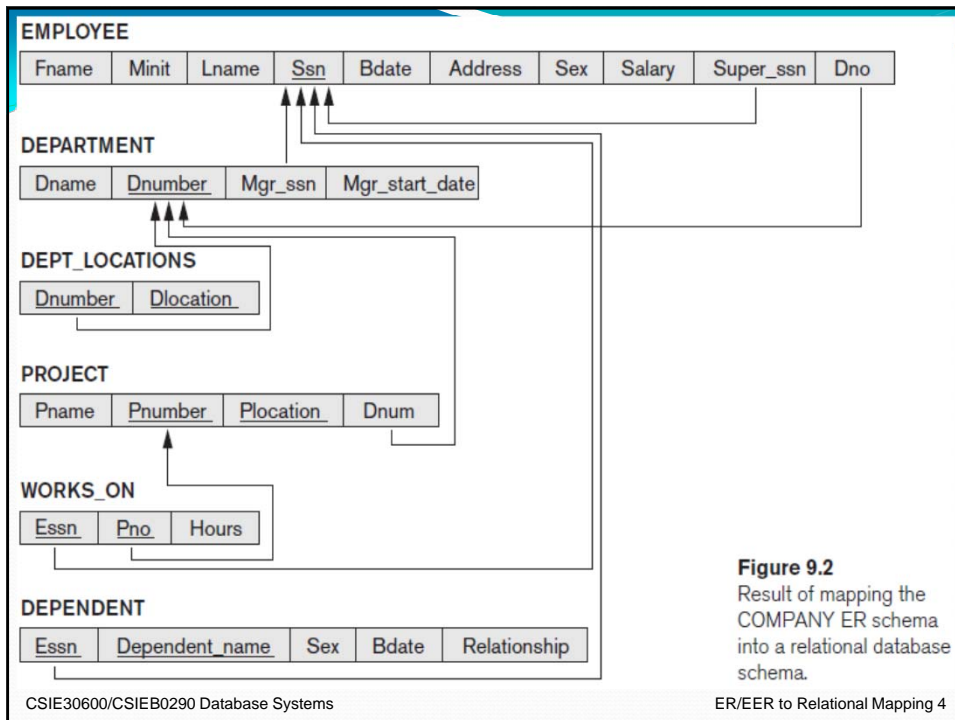
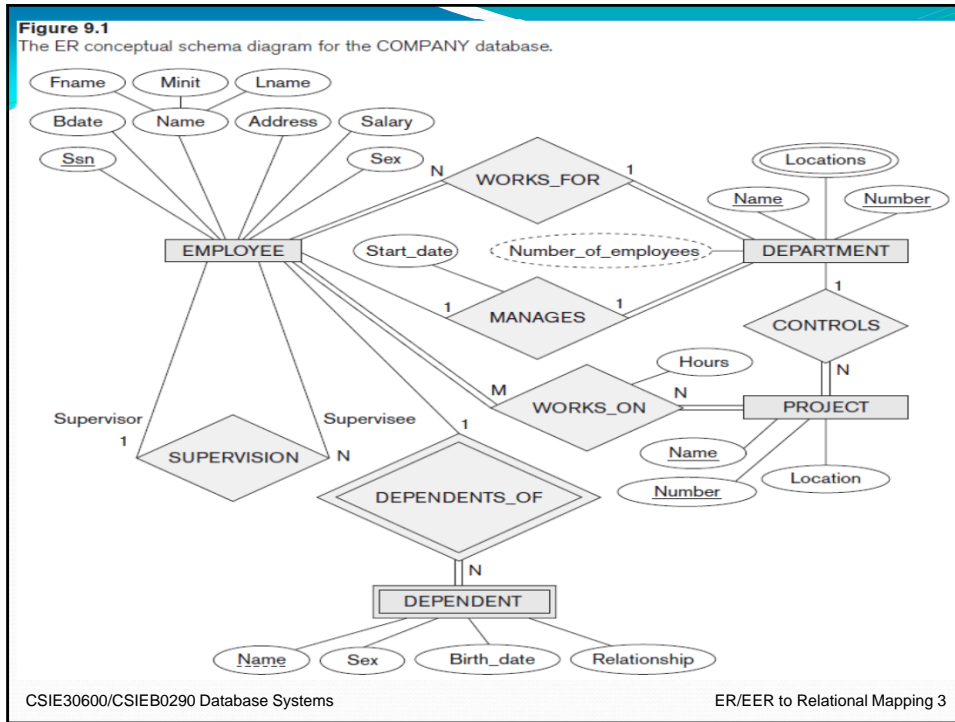

## Mapping Algorithm (Step 1)

- **Step 1: Mapping of Regular Entity Types.**
  - For each **regular (strong) entity type E**, create a **relation R** that includes all the **simple attributes** of E.
  - Choose one of the keys of E as the **primary key** for R.
  - If the chosen key of E is composite, the set of simple attributes together form the primary key of R.
- Example: Create the relations EMPLOYEE, DEPARTMENT, and PROJECT corresponding to the regular entities in the ER diagram.
  - SSN, DNUMBER, and PNUMBER are the primary keys for the relations EMPLOYEE, DEPARTMENT, and PROJECT as shown.

CSIE30600/CSIEB0290 Database Systems

ER/EER to Relational Mapping 5

## ER to Relational - Step 1

- **Step 1: Process regular entity types. (entity relations)**

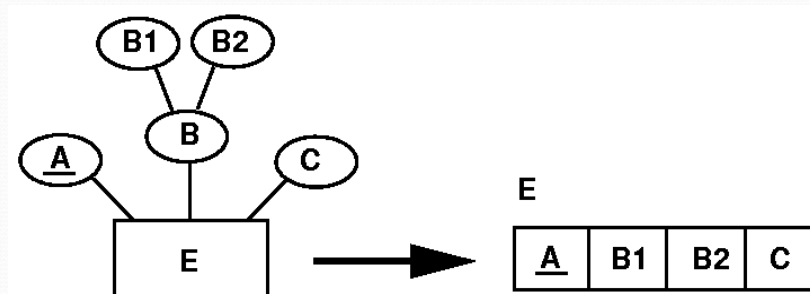

CSIE30600/CSIEB0290 Database Systems

ER/EER to Relational Mapping 6

## Mapping Algorithm (Step 2)

- **Step 2: Mapping of Weak Entity Types**

- For each **weak entity type** W in the ER schema with owner entity type E, create a relation R & include all simple attributes (or simple components of composite attributes) of W as attributes of R.
- Also, include as **foreign key** attributes of R the **primary key attribute(s)** of the **owner(s)**.
- The primary key of R is the **combination of the primary key(s) of the owner(s)** and the **partial key** of the weak entity type W, if any.

CSIE30600/CSIEB0290 Database Systems

ER/EER to Relational Mapping 7

## ER to Relational - Step 2

- **Step 2: Process weak entity types.**

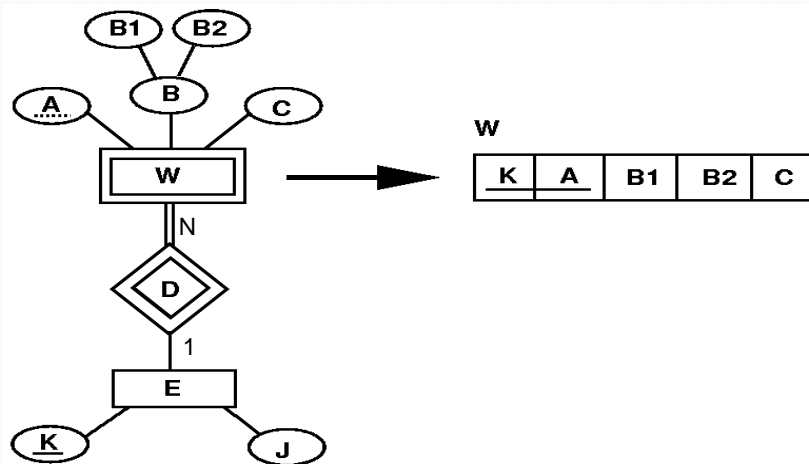

CSIE30600/CSIEB0290 Database Systems

ER/EER to Relational Mapping 8

## Step 2 (contd.)

- **Example:** Create the relation DEPENDENT in this step to correspond to the weak entity type DEPENDENT.
  - Include the primary key SSN of the EMPLOYEE relation as a foreign key attribute of DEPENDENT (renamed to ESSN).
  - The primary key of the DEPENDENT relation is the combination {ESSN, DEPENDENT\_NAME} because DEPENDENT\_NAME is the partial key of DEPENDENT.

## ER-to-Relational Mapping Algorithm (cont.)

**Figure 9.3**

Illustration of some mapping steps.

- (a) *Entity* relations after step 1.
- (b) Additional *weak entity* relation after step 2.
- (c) *Relationship* relations after step 5.
- (d) Relation representing multivalued attribute after step 6.

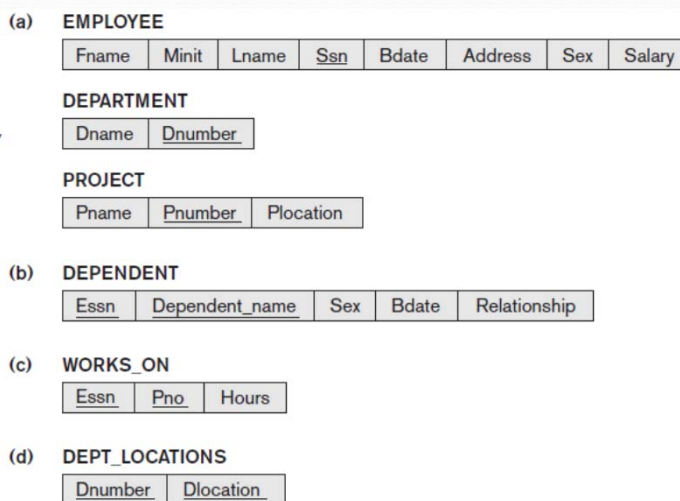

## Mapping Algorithm (Step 3)

- **Step 3: Mapping of Binary 1:1 Relation Types**

- For each binary 1:1 relationship type R in the ER schema, identify the relations S and T that correspond to the entity types participating in R.

- Three possible approaches:

1. **Foreign Key approach:** Choose one of the relations-say S-and include a foreign key in S the primary key of T. It is better to choose an entity type with **total participation** in R in the role of S.
  - Example: 1:1 relation MANAGES is mapped by choosing the participating entity type DEPARTMENT to serve in the role of S, because its participation in the MANAGES relationship type is total.

## Step 3 (cont.)

2. **Merged relation option:** An alternate mapping of a 1:1 relationship type is possible by merging the two entity types and the relationship into a single relation. This may be appropriate when **both participations are total**.
3. **Cross-reference or relationship relation option:** The third alternative is to set up a **third relation R** for the purpose of cross-referencing the primary keys of the two relations S and T representing the entity types.

## ER to Relational - Step 3

- Step 3: Process **1:1** relationships.

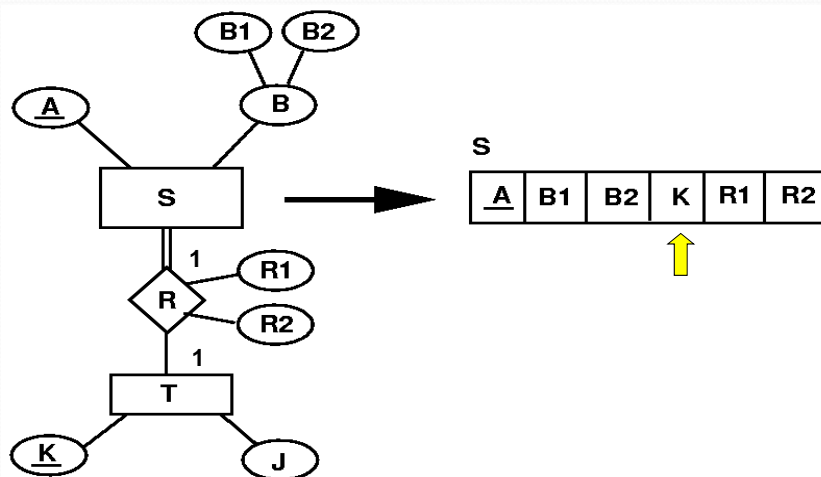

CSIE30600/CSIEB0290 Database Systems

ER/EER to Relational Mapping 13

## Mapping Algorithm (Step 4)

- **Step 4: Mapping of Binary 1:N Relationship Types.**
  - For each regular binary 1:N relationship type R, identify the relation S that represent the participating entity type at the **N-side** of the relationship type.
  - Include as **foreign key in S** the **primary key of the relation T** that represents the other entity type participating in R.
  - Include any simple **attributes** of the 1:N relation type as attributes of S.

CSIE30600/CSIEB0290 Database Systems

ER/EER to Relational Mapping 14

## ER to Relational - Step 4

- Step 4: Process 1:N relationships.

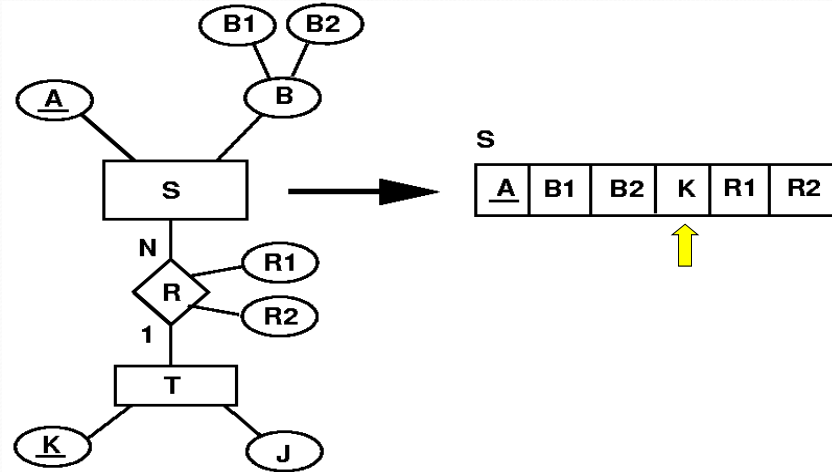

CSIE30600/CSIEB0290 Database Systems

ER/EER to Relational Mapping 15

## Step 4 (cont.)

- Example: 1:N relationship types WORKS\_FOR, CONTROLS, and SUPERVISION in the figure.
  - For WORKS\_FOR we include the primary key DNUMBER of the DEPARTMENT relation as foreign key in the EMPLOYEE relation and call it DNO.

CSIE30600/CSIEB0290 Database Systems

ER/EER to Relational Mapping 16



## Mapping Algorithm (Step 5)

- **Step 5: Mapping of Binary M:N Relationship Types.**

- For each regular binary M:N relationship type R, **create a new relation** S to represent R.
- Include as **foreign key** attributes in S the **primary keys** of the relations that represent the participating entity types; *their combination will form the primary key* of S.
- Also include any simple **attributes** of the M:N relationship type (or simple components of composite attributes) as attributes of S.

## ER to Relational - Step 5

- **Step 5: Process M:N relationships.**

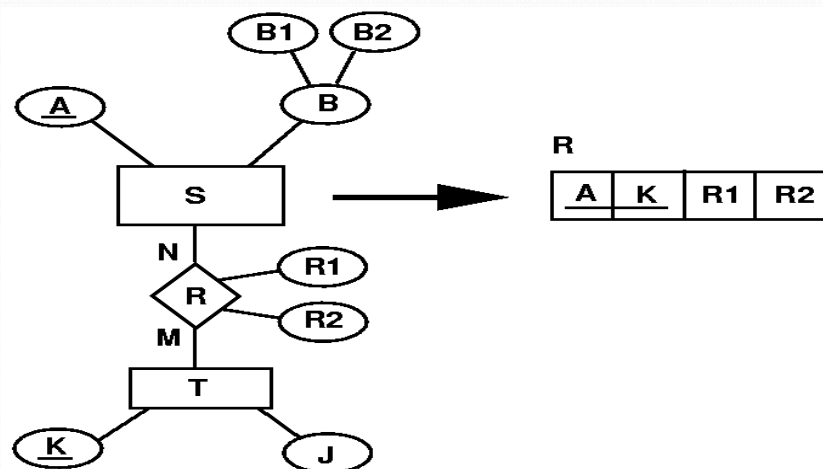

## Step 5 (contd.)

- Example: The M:N relationship type WORKS\_ON from the ER diagram is mapped by creating a relation WORKS\_ON in the relational database schema.
  - The primary keys of the PROJECT and EMPLOYEE relations are included as foreign keys in WORKS\_ON and renamed PNO and ESSN, respectively.
  - Attribute HOURS in WORKS\_ON represents the HOURS attribute of the relation type. The primary key of the WORKS\_ON relation is the combination of the foreign key attributes {ESSN, PNO}.

## Mapping Algorithm (Step 6)

- **Step 6: Mapping of Multivalued attributes.**
  - For each **multivalued attribute** A, create a **new relation** R.
  - This relation R will include an attribute corresponding to A, plus the **primary key** attribute K-as a **foreign key** in R-of the relation that represents the entity type of relationship type that has A as an attribute.
  - The primary key of R is the combination of A and K. If the multivalued attribute is composite, we include its simple components.

## ER to Relational - Step 6

- Step 6: Process **multivalued** attributes.

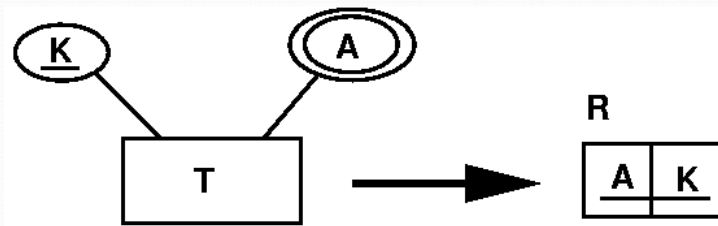

CSIE30600/CSIEB0290 Database Systems

ER/EER to Relational Mapping 21

## Step 6 (contd.)

- **Example:** The relation DEPT\_LOCATIONS is created.
  - The attribute DLOCATION represents the multivalued attribute LOCATIONS of DEPARTMENT, while DNUMBER- as foreign key-represents the primary key of the DEPARTMENT relation.
  - The primary key of R is the combination of {DNUMBER, DLOCATION}.

CSIE30600/CSIEB0290 Database Systems

ER/EER to Relational Mapping 22

## Mapping Algorithm (Step 7)

- **Step 7: Mapping of N-ary Relationship Types.**
  - For each n-ary relationship type R, where  $n > 2$ , create a **new relation S** to represent R.
  - Include as foreign key attributes in S the **primary keys of the relations that represent the participating entity types.**
  - Also include any simple **attributes** of the n-ary relationship type (or simple components of composite attributes) as attributes of S.

CSIE30600/CSIEB0290 Database Systems

ER/EER to Relational Mapping 23

## ER to Relational - Step 7

- **Step 7:** Process **n-array** relationship type for  $n > 2$ .

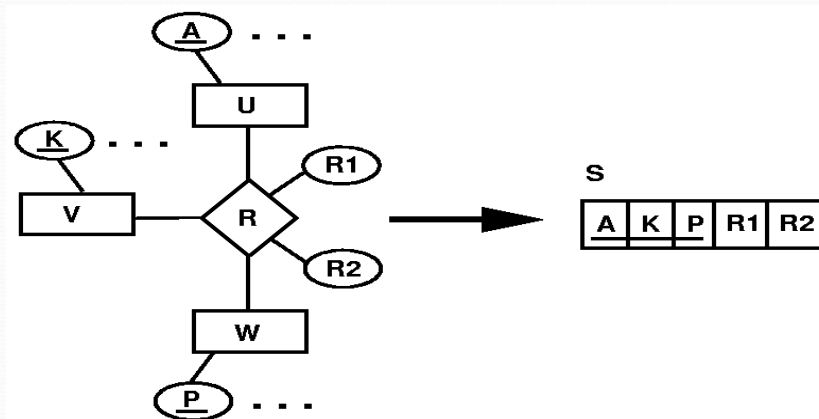

CSIE30600/CSIEB0290 Database Systems

ER/EER to Relational Mapping 24

## Summary of Mapping for ER Model Constructs

**Table 9.1** Correspondence between ER and Relational Models

ER MODEL	RELATIONAL MODEL
Entity type	<i>Entity</i> relation
1:1 or 1:N relationship type	Foreign key (or <i>relationship</i> relation)
M:N relationship type	<i>Relationship</i> relation and <i>two</i> foreign keys
<i>n</i> -ary relationship type	<i>Relationship</i> relation and <i>n</i> foreign keys
Simple attribute	Attribute
Composite attribute	Set of simple component attributes
Multivalued attribute	Relation and foreign key
Value set	Domain
Key attribute	Primary (or secondary) key

CSIE30600/CSIEB0290 Database Systems

ER/EER to Relational Mapping 25

## Mapping EER Model Constructs to Relations

- **Step 8: Mapping Specialization or Generalization.**
  - Convert each specialization with ***m* subclasses**  $\{S_1, \dots, S_m\}$  and generalized **superclass** ***C*** with attributes  $\{k, a_1, \dots, a_n\}$  and *k* is the (primary) key, into relational schemas:
    - Option 8A: Multiple relations-Superclass and subclasses
    - Option 8B: Multiple relations-Subclass relations only
    - Option 8C: Single relation with one type attribute
    - Option 8D: Single relation with multiple type attributes

CSIE30600/CSIEB0290 Database Systems

ER/EER to Relational Mapping 26

## Mapping EER Model Constructs to Relations

- **Option 8A: Multiple relations-Superclass and subclasses**

- Create a **relation L for C** with attributes  $Attrs(L) = \{k, a_1, \dots, a_n\}$  and  $PK(L) = k$ . Create a **relation Li for each subclass Si**,  $1 < i < m$ , with the attributes  $Attrs(Li) = \{k\} \cup \{\text{attributes of } Si\}$  and  $PK(Li)=k$ . This option works for any specialization (total or partial, disjoint or over-lapping).

## EER to Relational - Step 8

- **Step 8: Process superclass/subclass relationships.**
  - **Option 8A:** Create a relation for the superclass and a relation for each subclass with key attributes from the superclass.

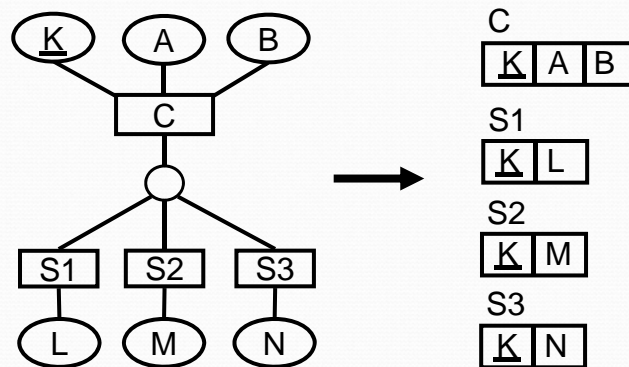

### EER diagram notation for an attribute-defined specialization on JobType.

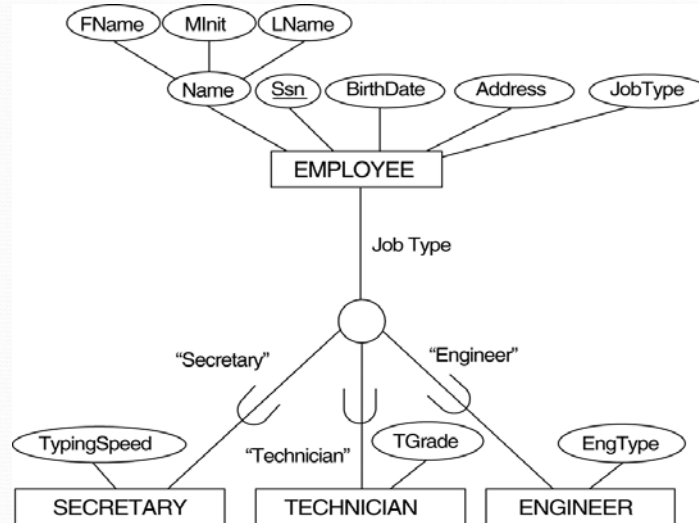

CSIE30600/CSIEB0290 Database Systems

ER/EER to Relational Mapping 29

### Options for mapping specialization or generalization. (a) Mapping the EER schema in last slide using option 8A.

(a) EMPLOYEE

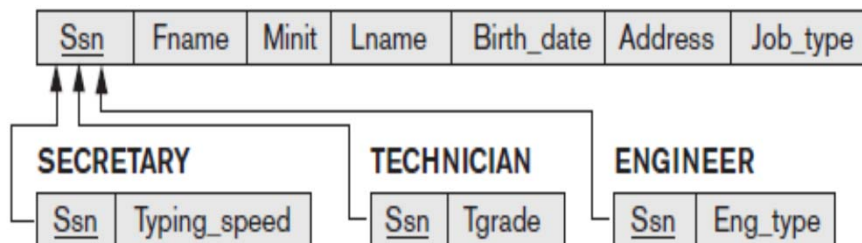

CSIE30600/CSIEB0290 Database Systems

ER/EER to Relational Mapping 30

## EER to Relational - Option 8B

- **Option 8B: Multiple relations-Subclass relations only**
  - Create a relation  $L_i$  for each subclass  $S_i$ ,  $1 < i < m$ , with the attributes  $\text{Attr}(L_i) = \{\text{attributes of } S_i\} \cup \{k, a_1, \dots, a_n\}$  and  $\text{PK}(L_i) = k$ . This option **only works for** a specialization whose subclasses are **total** (every entity in the superclass must belong to (at least) one of the subclasses).

CSIE30600/CSIEB0290 Database Systems

ER/EER to Relational Mapping 31

## EER to Relational - Option 8B

- **Option 8B:** Create a relation for each subclass with all attributes of the superclass.

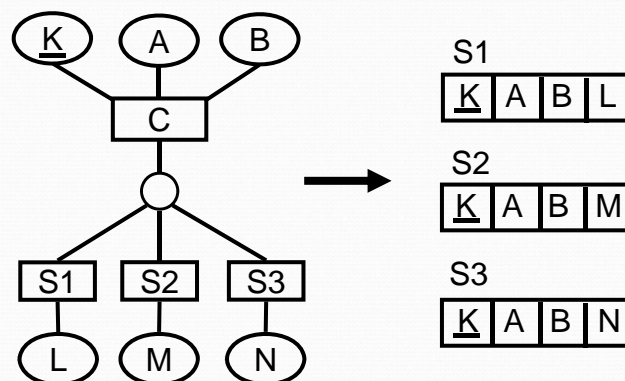

CSIE30600/CSIEB0290 Database Systems

ER/EER to Relational Mapping 32



## Generalization. (b) Generalizing CAR and TRUCK into the superclass VEHICLE.

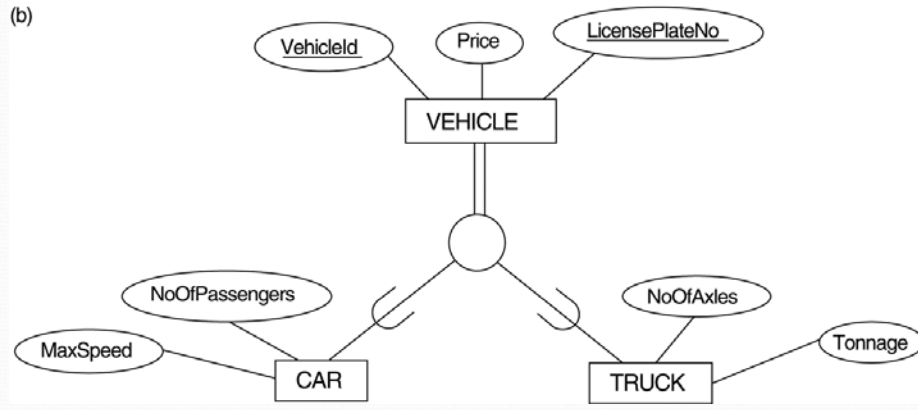

CSIE30600/CSIEB0290 Database Systems

ER/EER to Relational Mapping 33

## Options for mapping specialization or generalization.

### (b) Mapping the EER schema using option 8B.

(b) CAR

<u>Vehicle_id</u>	License_plate_no	Price	Max_speed	No_of_passengers
-------------------	------------------	-------	-----------	------------------

TRUCK

<u>Vehicle_id</u>	License_plate_no	Price	No_of_axles	Tonnage
-------------------	------------------	-------	-------------	---------

CSIE30600/CSIEB0290 Database Systems

ER/EER to Relational Mapping 34

## EER to Relational - Option 8C

- **Option 8C: Single relation with one type attribute**
  - Create a **single relation** L with attributes  $\text{Attrs}(L) = \{k, a_1, \dots, a_n\} \cup \{\text{attributes of } S_1\} \cup \dots \cup \{\text{attributes of } S_m\} \cup \{t\}$  and  $\text{PK}(L) = k$ . The attribute t is called a **type** (or **discriminating**) **attribute** that indicates the subclass to which each tuple belongs

CSIE30600/CSIEB0290 Database Systems

ER/EER to Relational Mapping 35

## EER to Relational - Option 8C

- **Option 8C:** Create a single relation with all attributes of superclass and subclasses, and a **type attribute**. (for *disjoin specialization*)

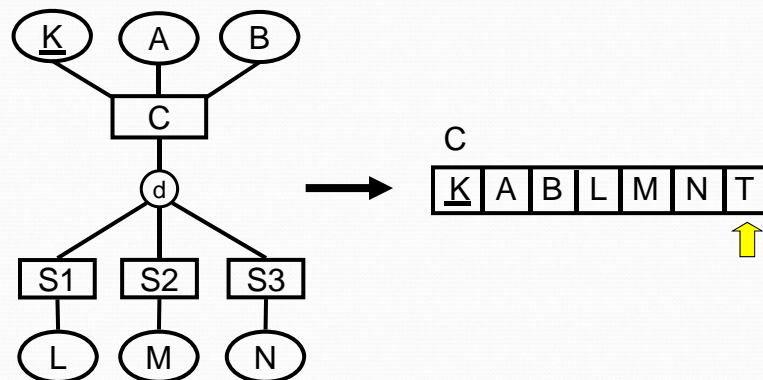

CSIE30600/CSIEB0290 Database Systems

ER/EER to Relational Mapping 36

### EER diagram notation for an attribute-defined specialization on JobType.

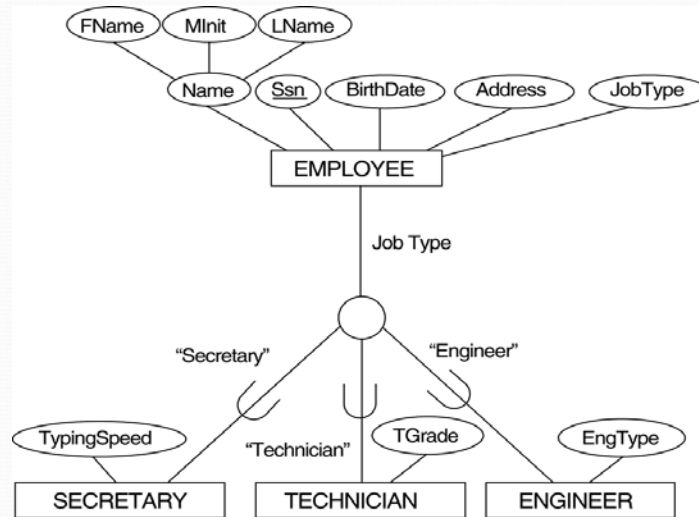

CSIE30600/CSIEB0290 Database Systems

ER/EER to Relational Mapping 37

### Options for mapping specialization or generalization.

(c) Mapping the EER schema in last slide using option 8C.

(c) EMPLOYEE

<u>Ssn</u>	Fname	Minit	Lname	Birth_date	Address	Job_type	Typing_speed	Tgrade	Eng_type
------------	-------	-------	-------	------------	---------	----------	--------------	--------	----------



CSIE30600/CSIEB0290 Database Systems

ER/EER to Relational Mapping 38

## EER to Relational - Option 8D

- **Option 8D: Single relation with multiple type attributes**
  - Create a **single relation** L with attributes  $\text{Attrs}(L) = \{k, a_1, \dots, a_n\} \cup \{\text{attributes of } S_1\} \cup \dots \cup \{\text{attributes of } S_m\} \cup \{t_1, t_2, \dots, t_m\}$  and  $\text{PK}(L) = k$ . Each  $t_i, 1 < i < m$ , is a **Boolean type attribute** indicating whether a tuple belongs to the subclass  $S_i$ .

## EER to Relational - Option 8D

- **Option 8D:** Create a single relation with all attributes of superclass and subclasses, and a set of **Boolean attributes**, one for each subclass. (for overlapping specialization)

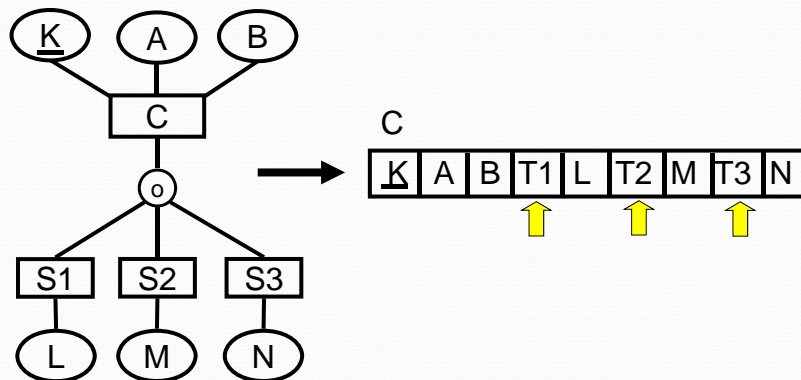

**EER diagram notation for an overlapping (non-disjoint) specialization.**

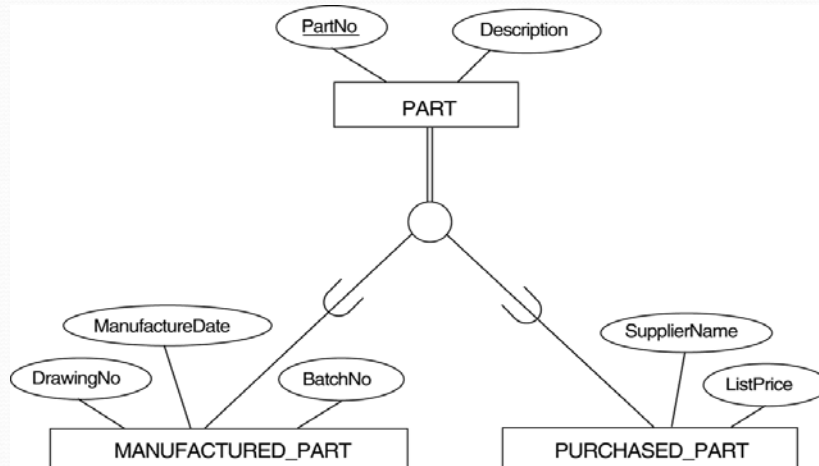

CSIE30600/CSIEB0290 Database Systems

ER/EER to Relational Mapping 41

**Options for mapping specialization or generalization.**

**(d) Using option 8D with Boolean type fields Mflag and Pflag.**

(d) PART

<u>Part_no</u>	Description	Mflag	Drawing_no	Manufacture_date	Batch_no	Pflag	Supplier_name	List_price
----------------	-------------	-------	------------	------------------	----------	-------	---------------	------------



CSIE30600/CSIEB0290 Database Systems

ER/EER to Relational Mapping 42

## Mapping of Shared Subclasses (Multiple Inheritance)

- **Mapping of Shared Subclasses**

- A shared subclass is a subclass of several classes, indicating **multiple inheritance**. These classes must all have the same key attribute; otherwise, the shared subclass would be modeled as a category.
- We can apply any of the options discussed in Step 8 to a shared subclass, subject to the restriction discussed in Step 8 of the mapping algorithm. Below both 8C and 8D are used for the shared class STUDENT\_ASSISTANT.

CSIE30600/CSIEB0290 Database Systems

ER/EER to Relational Mapping 43

## A specialization lattice with multiple inheritance for a UNIVERSITY database.

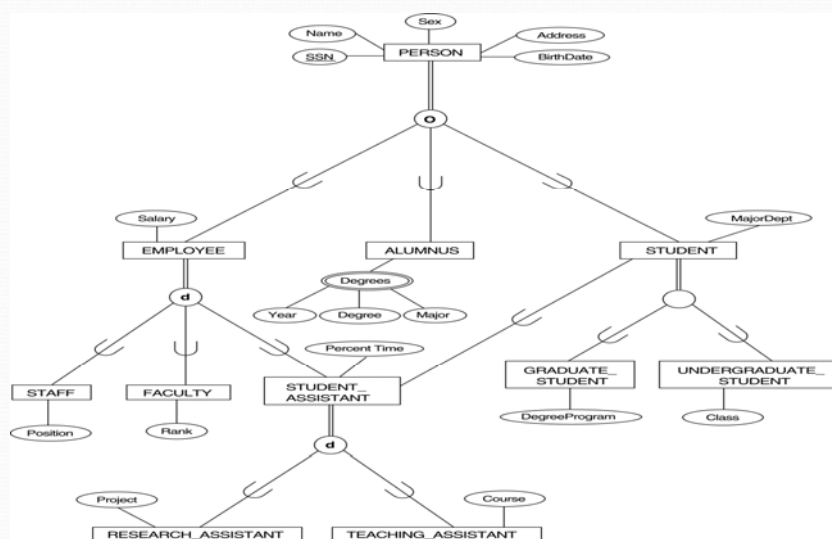

CSIE30600/CSIEB0290 Database Systems

ER/EER to Relational Mapping 44

## Mapping the EER specialization lattice using multiple options.

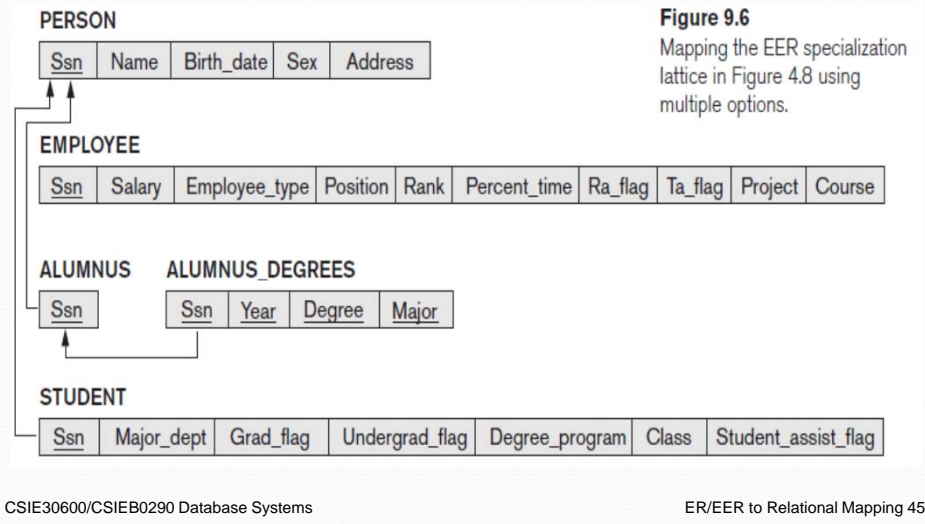

## Mapping of Categories (Union Types) – Step 9

- **Step 9: Mapping of Union Types (Categories)**
  - Defining superclasses have different keys
  - Specify a new key attribute
    - **Surrogate key**

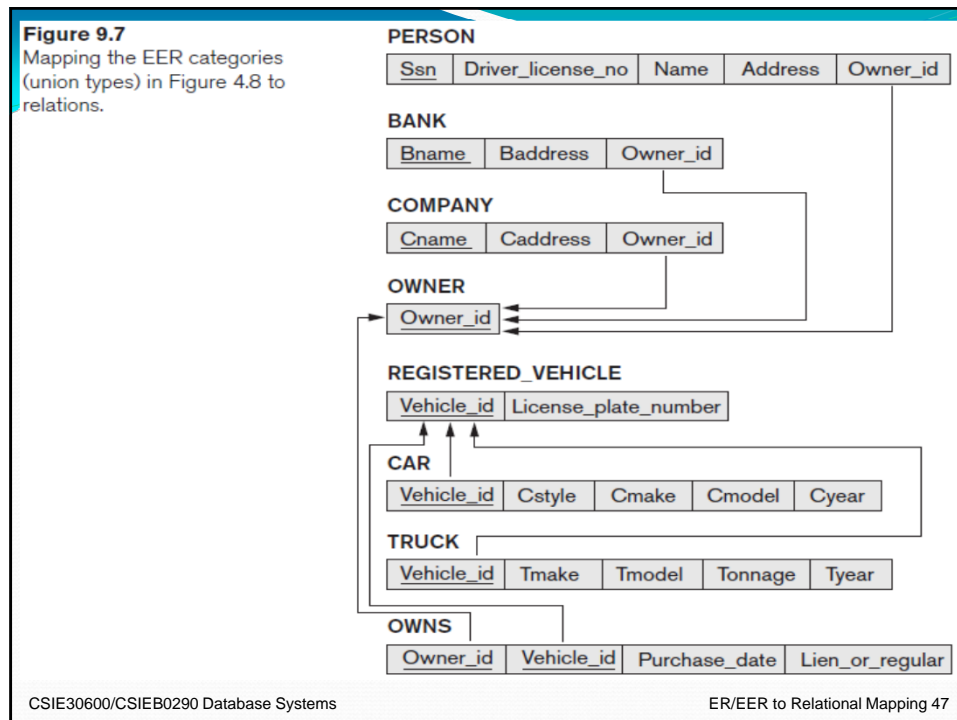

## Summary

- **ER-to-Relational Mapping Algorithm**
  - Step 1: Mapping of Regular Entity Types
  - Step 2: Mapping of Weak Entity Types
  - Step 3: Mapping of Binary 1:1 Relation Types
  - Step 4: Mapping of Binary 1:N Relationship Types.
  - Step 5: Mapping of Binary M:N Relationship Types.
  - Step 6: Mapping of Multivalued attributes.
  - Step 7: Mapping of N-ary Relationship Types.
- **EER Model Constructs to Relations**
  - Step 8: Options for Mapping Specialization or Generalization.
  - Step 9: Mapping of Union Types (Categories).